



Saba Centra Live Version 7.5  
Participant Getting Started Essentials



Saba Centra Live

Version 7.5

Participant Getting Started Essentials

Part Number: 188971

April 2007

### **Limitations on Warranties and Liability**

Saba Software, Inc. reserves the right to make changes in information contained in this document without notice.

In no event shall Saba or its suppliers be liable for any damages whatsoever (including, without limitation, damages for loss of business profits, business interruption, loss of business information, or any other pecuniary loss) arising out of or relating to this documentation or the information contained in it, even if Saba has been advised of the possibility of such damages and whether arising from tort (including negligence), breach of contract or otherwise.

This document may only be reproduced and distributed in whole for use by licensed users. No part of this document may be reproduced in any form for any other purpose without the prior written consent of Saba Software, Inc.

The software described in this documentation is copyrighted and is confidential information and a proprietary product of Saba Software, Inc.

**U.S. GOVERNMENT RESTRICTED RIGHTS.** If licensee is the United States Government or any contractor thereof, all licenses granted in the License Agreement accompanying this product are subject to the following: (i) for acquisition by or on behalf of civilian agencies, as necessary to obtain protection as "commercial computer software" and related documentation in accordance with the terms of this Commercial Software Agreement as specified in 48 C.F.R. 12.212 of the Federal Acquisition Regulations and its successors; (ii) for acquisition by or on behalf of units of the Department of Defense ("DOD") as necessary to obtain protection as "commercial computer software" and related documentation in accordance with the terms of this commercial computer software license as specified in 48 C.F.R. 227-7202-2 of the DOD F.A.R. Supplement and its successors.

Saba, the Saba logo and Centra are registered trademarks of Saba Software, Inc. and Saba and Saba Centra product names are the trademarks of Saba Software, Inc. All other product names mentioned in this manual are the property and may be trademarks or registered trademarks of their respective owners, and are used for identification purposes only.

© 2007 Saba Software, Inc. All rights reserved.

# Table of Contents

<b>Getting Started .....</b>	<b>1</b>
<b>Introduction .....</b>	<b>1</b>
<b>Attending an Event.....</b>	<b>1</b>
Attending from an email message.....	1
Attending From My Schedule page .....	1
Accessing Public Events.....	1
Registered Users Only Events.....	1
<b>Using Public Navigation Bar .....</b>	<b>1</b>
<b>Centra Connectivity Tips .....</b>	<b>2</b>
<b>Connecting a Headset .....</b>	<b>3</b>
<b>Participant Reference .....</b>	<b>4</b>
Entering a Session.....	4
<b>Running the Audio Wizard .....</b>	<b>4</b>
During the Session.....	5
<b>Speaking.....</b>	<b>5</b>
<b>Adjusting Audio During a Session .....</b>	<b>5</b>
<b>Sending Text Chat .....</b>	<b>5</b>
<b>Markup Tools .....</b>	<b>5</b>
<b>Participant Tips .....</b>	<b>5</b>
Planning .....	5
Changing the View .....	5
Floating Toolbar in Full Screen View.....	6
<b>Creating a Centra eMeeting.....</b>	<b>6</b>
Seat Availability .....	6
Meeting Options .....	6
Audio Options.....	6
Attendees .....	7
<b>Where to Get More Information .....</b>	<b>7</b>



# Getting Started

## Introduction

**Online Help**, is accessible from the Centra Home page.

The **Centra Symposium, Conference, and eMeeting Participant Tutorials** are accessible from the Centra Welcome page.

**Note:** The Centra server may not have all the listed features enabled. Contact the System Administrator for assistance.

## Attending an Event

There are several ways to attend a Centra Event:

- From a link in an email message
- From the My Schedule page
- From the Public Events page.

### *Attending from an email message*

1. Click the link in your email message.
2. Type in your **Email address** and click **Attend**  
or

Type your **Login** and **Password**.

**Note:** If you encounter errors or cannot access a page, contact your System Administrator.

3. If necessary, type a **First name, Last name, Display name**, and optionally **Password**. Click **Attend**.

### *Attending From My Schedule page*

Before attending a session, click **System Check** to check if the system can successfully support a session.

1. Click the **My Schedule** link to access your Centra Home page and locate the session that you want to attend.

**Note:** A login and password are required to access the My Schedule page.

2. If **Download** link appears, click this link.
3. Select **Automatic Download**
4. Click **Proceed**.
5. Click **Attend**. If the client is:
  - Installed, access the session.
  - Not installed, a prompt appears to download the client.

**Note:** When using Netscape, accept the Netscape plugin (if needed). The client will be installed automatically.

6. Click **Yes** in the Security dialog box.

## *Accessing Public Events*

The Public Events page enables users to access public events. When this page is selected as the domain home page (the default in a new installation), users need only the domain URL to access a list of public events.

The Public Events page contains the following features:

- The public navigation bar
- Search Field
- Public events list

## Attending Public Events

Participants can attend an event by clicking the Attend link.

## *Registered Users Only Events*

Some events restrict attendance to registered users. Although the event appears in the Public Event List that is shown to users who have not logged in, users can attend this event only by providing the user name and password of a registered account.



## Using Public Navigation Bar

The public navigation bar appears on the left side of pages that users access without logging in. The public navigation bar contains links to other pages.

Three of the links in the public navigation bar point to other pages that users can visit without logging in:

- Public Events
- Public Recordings
- Create Account

The other links in the public navigation bar provide shortcuts to pages that users cannot visit without first logging in:

- My Schedule
- Create Meeting

When users click the My Schedule or Create Meeting link, they are first directed to the Log In page. After logging in, they are directed to the My Schedule or Create Meeting page.

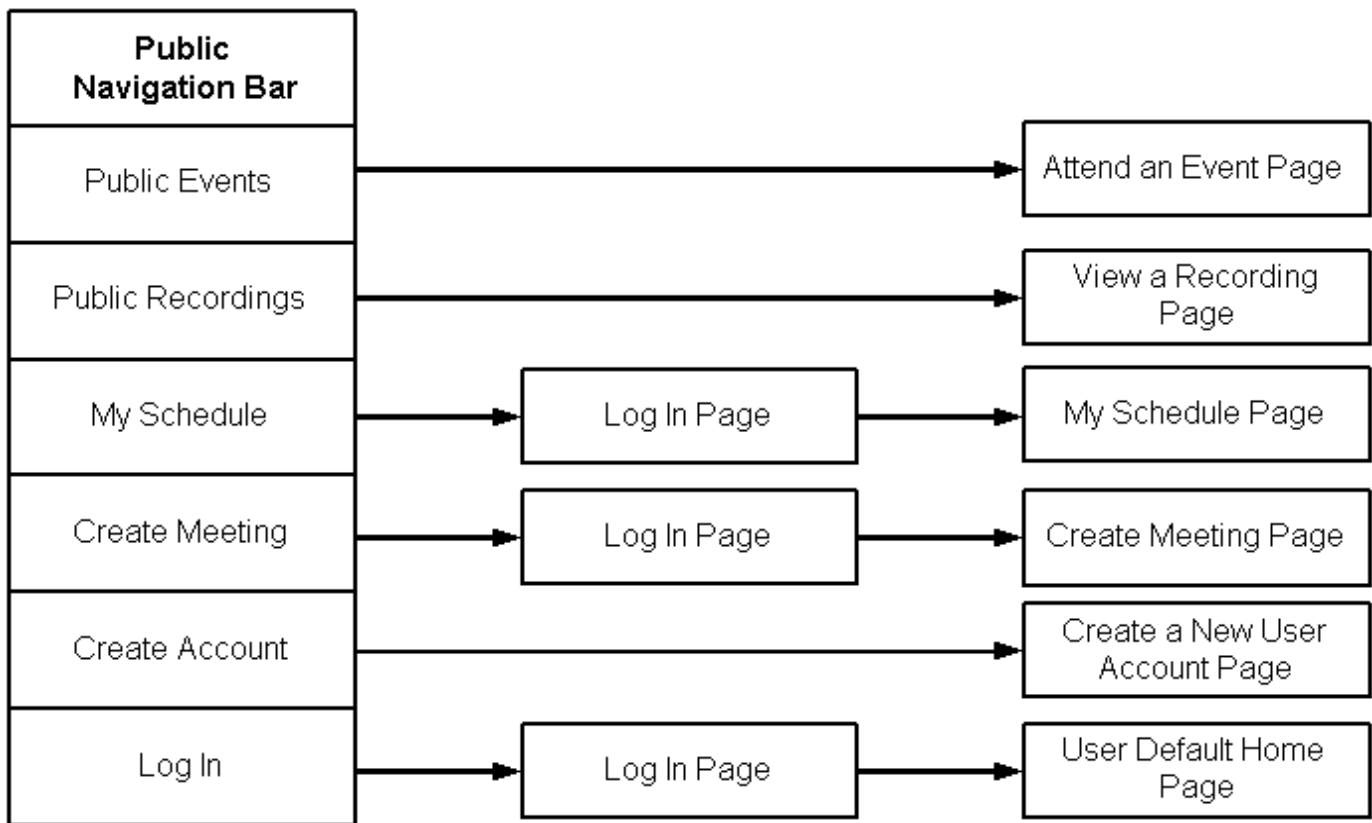

## Centra Connectivity Tips

**Note:** Running other applications while in session can slow the session.

### Receive a “Page not found” error:

Make sure you have the correct Web address (URL) and that you typed the address correctly. Confirm the URL with your Centra or IT Administrator.

### Access the Centra Welcome page but cannot log in:

Make sure that you are typing your login name and password correctly. **Note:** Passwords are case sensitive.

Verify that you have a Centra user account.

or

Click the **Forgot my password** link (if it is available) and follow the instructions.

### Access the Centra Home page (My Schedule page) but cannot find the session:

Click the Past or Ongoing tabs to check if the session has already occurred, is ongoing or a Public Event for Self Enrollment.

### Click the Attend or Lead link, but the Centra client does not launch:

A “login ID already in use” message indicates that you are already attending the session on another PC, using the same ID as another user, have another version of the client open, or clicked the Attend link more than once.

If you see the Centra Setup window, follow the instructions in the window to install the client.

If you see this window more than once, you may be attending the session on a different server. If cookies are disabled in your browser, enable them to avoid seeing this window every time you attend a session.

If none of the other solutions apply, restart the PC.

### Have trouble connecting to the Session or Centra server:

Close all other applications on your computer or reboot your machine.

## Connecting a Headset

Using audio in a Centra session requires a headset/microphone or a separate microphone and speakers.

1. Locate the icons for microphone and speaker on the plugs of your headset.
2. Match the icons on the plugs to the jacks on your computer.
  - The microphone jack may have the word "mic," or a picture of a microphone.

- The speaker jack may have the word "out," or a picture of a speaker.
3. Plug the headset/microphone or a separate microphone and speakers to the computer.
  4. Make sure the volume control on your computer is turned up.
  5. In session, test your audio with the Centra Audio Wizard.

## If you continue to have problems

Contact your Centra or IT Administrator or Centra Technical Support.

# Participant Reference

## Entering a Session

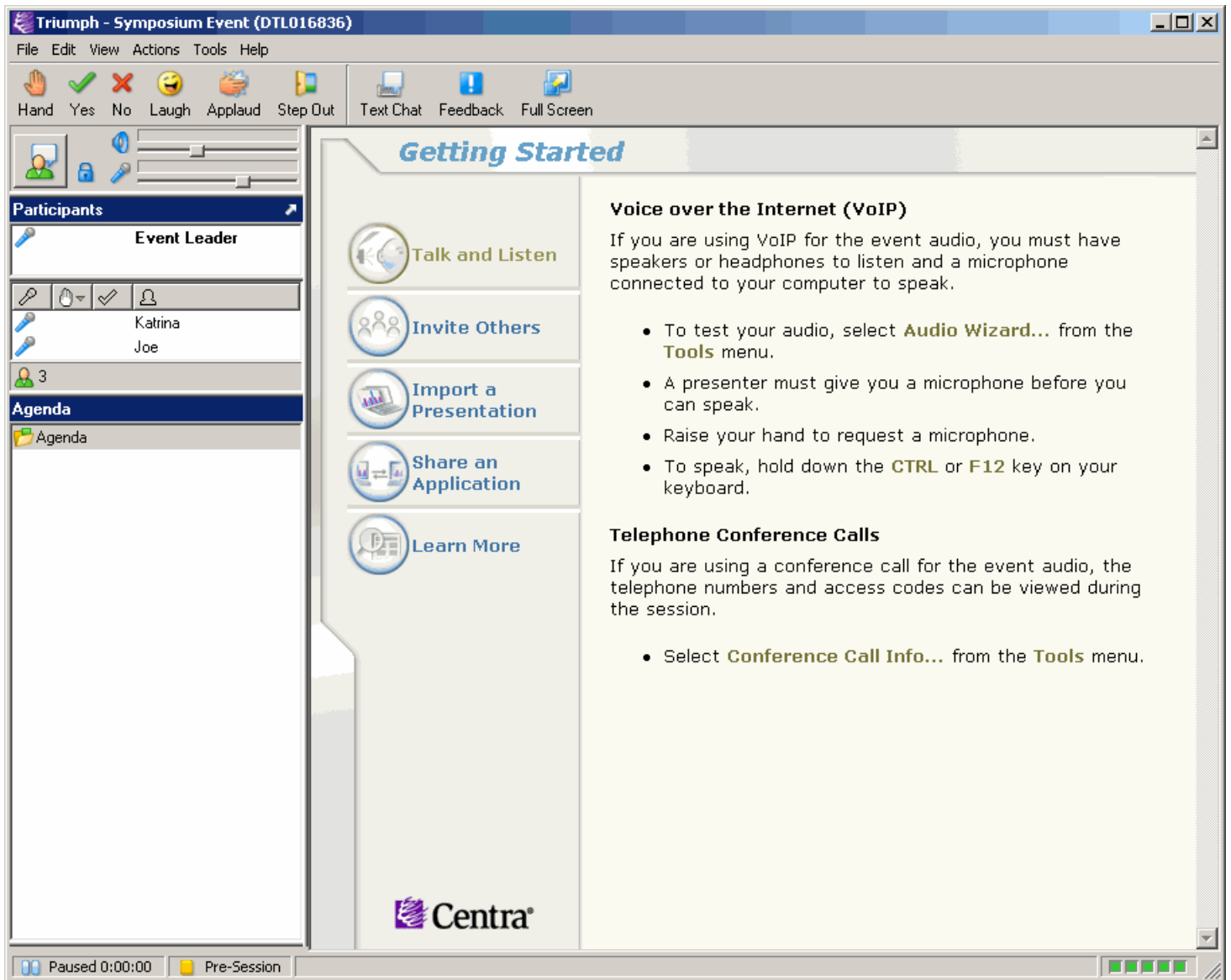

When entering a session, the Audio Wizard starts automatically. It is important to hear the Leader and others. Use the Centra Audio Wizard if there are problems with the audio.

## Running the Audio Wizard

In the Centra window, click **Tools** in the main menu and choose **Audio Wizard**.

1. Adjust the Playback volume using the slider to a comfortable level. When done, click **Next**.
2. Specify the appropriate audio device. Click **Next**.
3. Speak into the microphone. Optimal speaking levels are green in color, moving towards red.
4. Adjust the Recording volume to a suitable level using the slider. When done, click **Next**.
5. Click **Finish**.

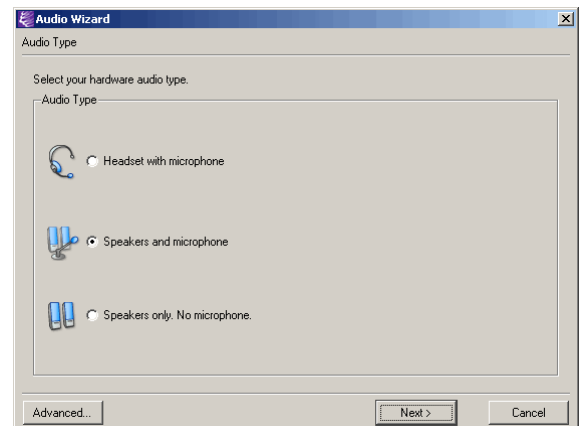

## A Note about Audio

A participant's audio type is displayed when the mouse passes over the participant in the Participants panel:

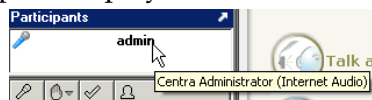









Users can change their audio type at any time during a session.

Phone-only users can participate in Unified Conferencing sessions, but are not included in the Participants panel.

## During the Session

The following functions are available to the participant during a session:

- |   |  |
|---|--|
|    | Click <b>Hand</b> to ask a question or request a microphone.                                       |
|    | Click <b>Yes</b> to respond to a question.   |
|    | Click <b>No</b> to respond to a question.  |
|   | Click <b>Laugh</b> to show amusement!  |
|  | Click <b>Applaud</b> to show approval.   |
|  | Click <b>Text Chat</b> to communicate with the Leader or other participants.                       |
|  | Click <b>Step Out</b> to step out. Use this function so others know that you are temporarily away. |
|  | Click <b>Feedback</b> to provide information to the Leader or the Presenter regarding the session. |
|  | Click <b>Full Screen</b> to expand the Participant interface to full screen size.                  |

## Speaking

Press and hold the **Control** key, and speak into your microphone.

Or

Click the **Lock to Talk** button  to speak for an extended time.

## Adjusting Audio During a Session

Use the slide next to the  icon to adjust the audio during an event.

## Sending Text Chat

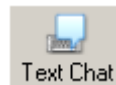

1. Click the **Text Chat** button.
2. Type a message in the text box.  
**Note:** The message is addressed to all participants and presenters unless you select a specific name from the **To** drop-down list.
3. Click **Send**.

## Markup Tools

(Not available in Conference)

Click the appropriate tool to mark up a slide on Whiteboard.

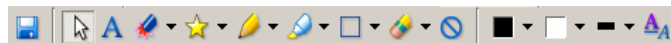

These tools are available when the whiteboard or an image (.gif or .jpg) is displayed.

**Note:** These tools are not available for PowerPoint files that are uploaded as HTML.

## Participant Tips

### Planning

- Browse course content before a session begins.  
**Note:** The ability to browse the content may be disabled.
- When experiencing a technical problem, close the session and then rejoin.

### Changing the View

1. Click **View** menu.
2. Select one of the following options:

**Normal View** - Returns your Participant interface from Full Screen or Application Host View to the previous settings.

**Full Screen View** - Expands your Participant interface to full screen size.

**Return to Default Size** - Returns your Participant interface to the default size (800 x 600) if you resized the window.

## Floating Toolbar in Full Screen View

In Full Screen view, the Centra toolbar floats and is transparent when the mouse pointer is not over it. Participants can drag a floating toolbar by its title bar to any part of the screen, and they can dock a floating toolbar by double-clicking its title bar.

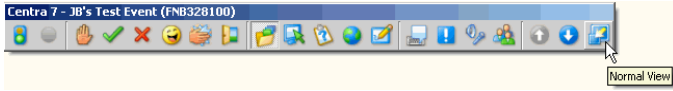

In Full Screen view, the media window occupies the entire screen, making it possible to display many shared applications in their entirety, without scrollbars. (It may not be possible to display a shared application in its entirety if the host's screen resolution is greater than the viewer's.)

## Creating a Centra eMeeting

**Note:** Only available through the Create Meeting link. If this link does not exist, eMeeting is not available.

A meeting is a quick way to collaborate with a group of people. Any user can schedule a meeting. The individual who creates the meeting is automatically the Leader and controls who is invited. It is not possible to attach a Subject and Agenda to a meeting, but it is possible to import content while in session.

Meetings do not appear on the public Event List unless Public is specified during the creation process.

The Create Meeting page is separated into the following sections:

- Schedule
- Seat Availability
- Meeting Options
- Audio Options
- Attendees

Use the following instructions to quickly create a meeting:

Click **Create Meeting** on the My Schedule page or other Centra pages.

### Schedule

**Note:** Using the Start Now option immediately begins the meeting. Otherwise, the other sections allow specifying options to customize the meeting.

1. Type the name (up to 60 characters) of the meeting in the **Name** field.
2. Select the **Day** from the calendar drop-down menu. Today's date is shown by default.

3. Select the **Time** from the drop-down menu, and a time zone, if necessary.
4. Select a **Duration**.
  - Select specific hours and minutes (available in 15 minute increments) from the drop-down menus to schedule the meeting at a specific time.
  - Select Ongoing if the meeting needs to be available all the time.
5. Select a Cost Center, if applicable.
6. Type a Description (Optional)

To start the meeting immediately and not set additional options, click Start Now. Otherwise, continue.

If Start Now is selected, the eMeeting Leader interface opens.

### Seat Availability

1. Select the number of people who can attend from the Seats Reserved list.

**Note:** The Event Manager sets the limit and it cannot be exceeded. The total number includes the meeting leader.
2. Click Seat Availability to verify how many seats are available for the specified time.

### Meeting Options

1. Choose the following meeting options:
  - Public event (The event appears on the public event list and allows users to self-enroll)
  - Record meeting (Permits recording the meeting for participants who would like to review the content or for individuals who were not able to participate.)
  - Live video (Permits live video to run)
  - Include live video in recording (Permits adding the video to the recording for playback)
  - Allow users to attend without an invitation. (This allows guest users to attend.)
2. Password-protect the meeting by typing (up to 50 characters) a meeting password.

### Audio Options

Select one of the following the Audio Options:

- Select **Voice Over Internet (VOIP)**. Accept the default or choose the appropriate audio option.

- Select **Telephone**.
  1. Type the phone numbers used to join the teleconference
  2. Type the access code in the Access Code field.
  3. Type Host code if necessary.
  4. Type the Conference Call Instructions. These instructions will be included with the notification email.

If the default teleconference information is part of your User Profile, the information appears by default. Change it if necessary.

While participating in the event, Participants can view the teleconference information.

If the Telephone option is selected, users have the option of using VOIP during the event.

### *Attendees*

1. Type the email address of each Participant in the **Email Address** area.
  2. Click **Done** to send the meeting invitation
- Or
- Click **Edit Attendees**

#### **Edit Attendees**

1. Click **Edit Attendees**. The Edit Attendees: Meeting Topic (Meeting ID) page opens. The Meeting Topic is the topic of the meeting and Meeting ID is the ID of the meeting.
2. Click the **Invite Attendees** tab.
3. Locate the name of the user or group of users to enroll.
4. Click **Invite** associated with the user or group.
5. Enroll multiple users or groups by performing the following:
  - Select the users and/or groups by selecting the checkbox next to their logins and then click Invite Selected.

- Click **Select All** to select all users and groups on the page. The users or groups are immediately invited to the meeting. Inviting a group invites all the individual users in that group.
  - Click **Unselect All** to exclude all the currently checked users. If the Centra domain has email enabled, update the Subject, and enter a message.
6. Click **Send Email** to send the email.

Or

Click **Cancel Email** to cancel the email; the user is still invited.

**Note:** If the Centra Server is set to add calendar attachments, the email automatically includes a calendar attachment. The recipient double-clicks the calendar attachment and saves it; a new calendar item is automatically created in the recipient's calendar. Contact your Centra System Administrator to enable/disable this feature.

Centra emails use the BCC field for all email addresses so that attendees do not learn the email addresses of other attendees. Centra Administrators do not receive their password in the email.

When the Edit Attendees: Meeting Topic page re-opens, the last column on the right updates to "Invited" to indicate the user(s) or groups have been invited. When a Group is invited, all users in the group are also marked as Invited.

If a Group is invited to a meeting, the invitation cannot be removed for specific individuals in that group without removing the invitations for the entire group.

The meeting now appears on your My Schedule page.

## Where to Get More Information

For information about Centra training, Documentation, and Knowledge objects, please see *Getting Information about Centra 7*.

saba® 